

International Journal of Engineering Sciences & Research Technology

(A Peer Reviewed Online Journal)

Impact Factor: 5.164



Chief Editor

Dr. J.B. Helonde

Executive Editor

Mr. Somil Mayur Shah

**INTERNATIONAL JOURNAL OF ENGINEERING SCIENCES & RESEARCH
TECHNOLOGY****USING A DYNAMIC VOLTAGE RESTORER (DVR) FOR REMOVAL OF
ABNORMALITIES DUE TO VOLTAGE SAG IN A DOUBLY FED TRANSMISSION
LINE****Seraj Ahamad¹, Ajit Kumar Verma² & Balram Yadav³**¹M.tech. Scholar, Department of Electrical Engineering, Scope college of engineering, Bhopal²Assistant Professor, Department of Electrical Engineering, Scope college of engineering, Bhopal³HOD, Department of Electrical Engineering, Scope college of engineering, Bhopal

DOI: 10.5281/zenodo.1462685

ABSTRACT

Changing electric load and higher power move in a wide interconnected framework prompts authentic, security require in charge structure assignments moreover if a sudden accuse occurs there is an alteration in voltage profile which can incite a sudden mischief on stack end. These voltage hangs are compensated at generator side by various strategies anyway at the load end there is a probability. to keep up a vital separation from such hang at stack side a tangle lab demonstrate is proposed in which a transmission line is sustained with two sources out of which one is a breeze source and after that is subjected to a 3 organize fault. the voltage hang which happens is compensated in the other model at same minute when DVR Dynamic voltage restorer is altered and is related at the midpoint of framework. The results got exhibits that the voltage is compensated and profile is balanced, DVR uses the essentialness source in all around facilitated way and implants nessacary AC voltage to arrange.

Keywords: DVR,matlab simulation ,short transmission line,DFIG**1. INTRODUCTION**

Power quality is of extraordinary significance in every cutting edge condition where power is included, control quality can be basically impacted by an essential factor like quality administration. One of the real worries in power industry today is control quality issues. By and by, the vast majority of the power quality issues are because of various blame conditions. These conditions cause voltage hang, voltage swell, homeless people, voltage intrusion and music. These issues may cause the mechanical assembly stumbling, shutdown business, household and modern hardware, and miss procedure of drive framework.

2. POWER QUALITY PROBLEMS, CAUSES AND EFFECTS

The various power quality problems are as followed:

- (i) 1.Transients- A transient is a temporary occurrence of a fault which is of a very short duration in a system caused by the sudden change of state.
- (ii) 2.Voltage sags- A voltage sag or voltage dip is a short duration reduction in rms voltage which can be caused by a short circuit, overload or starting of electric motors. A voltage sag happens when the rms voltage decreases between 10 and 90 percent of nominal voltage for one-half cycle to one minute
- (iii) 3.Voltage swells- Voltage swell, which is a momentary increase in voltage, happens when a heavy load turns off in a power system.
- (iv) 4.Voltage interruption- Interruptions are classified as short-duration or long-duration variation. The term interruption is often used to refer to short-duration interruption, while the latter is preceded by the word sustained to indicate a long-duration. They are measured and described by their duration since the voltage magnitude is always less than 10% of nominal.
- (v) 5.Harmonics- Harmonics is the integral multiple of frequencies voltages and currents in an electric power system due to non linear loads. Harmonic frequencies in the power grid are a frequent cause of power quality problems.

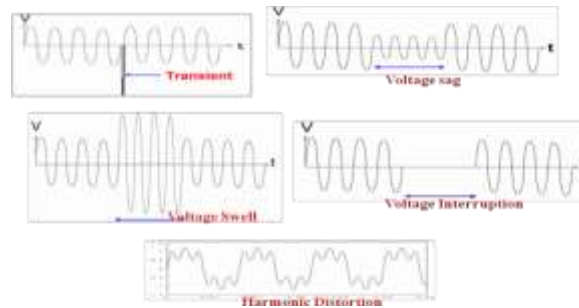

Fig. 1. Power Quality Problems

Causes of Power Quality Problems:

Transient – Due to Lightning, Turning major equipment on or off, back to back capacitor energization.

Voltage Sags – Due to starting of large Motors, Energization of heavy loads, incorrect VAR compensation.

Voltage Swells – Energizing a large capacitor bank, Switching off a large load, incorrect VAR compensation

Interruption – Faults (Short circuit), Equipment failures, Control malfunctions (attempting to isolate electrical problem).

Harmonics – IT equipment, Variable frequency drives, Electro Magnetic Interference from appliances, fluorescent lighting, Arc Furnace (Any non linear load).

Effects of Power Quality Problems:

Transient – Tripping, Processing error, Data loss, hardware reboot required, Component failure.

Voltage Sags--Dim lights, Equipment shutdown, Data error, shrinking display screens, Memory loss.

- Voltage Swells –Bright lights, Data error, shrinking display screens, Memory loss.
- Interruption – Faults, Equipment failures, Control malfunctions
- Harmonics – Line current increases, Losses increase, transformer and neutral conductor heating leading to reduced equipment life span.

DFIG: Variable speed wind turbines are more popular than fixed speed one, due to its ability to capture more energy from wind, improved power quality and reduced mechanical stress on the wind turbine. One of the most frequently used generators with variable speed wind turbines is the DFIG which is an interesting alternative with a growing market. It can run at variable speed but produce a voltage at the frequency of the grid. In contrast to a conventional simple induction generator the electrical power generated by a DFIG is independent of the speed. DFIG has various advantages like its low converter rating (The converter rating of the DFIG is 25-30% from the machine rating) consequently its relatively high efficiency, lighter in weight, its low cost and its capability of decoupling the control of both active and reactive power. Therefore, the DFIG has its distinguished place among many variable speed wind turbine generators.

DFIG consists of a wound rotor induction generator (WRIG) and bidirectional back-to-back voltage source converters. In this arrangement the stator is directly connected to the grid through a transformer while the rotor winding is connected via slip rings. to the stator or the grid through the two back-to-back converters. The back-to-back converter consists of two converters, i.e., rotor side converter (RSC) and grid side converter (GSC) (two AC/DC insulated gate bipolar transistor (IGBT) based Voltage Source Converters (VSCs)). A DC link capacitor is located between the two converters as energy storage, in order to maintain the variations (or ripple) in the DC link voltage small. The main function of the RSC is to control the torque or the speed of the DFIG and also the power factor at the stator terminals. On the other hand the function of the GSC is to keep the DC link voltage constant also in some cases it may inject reactive power into the grid. The variable speed operation of the wind turbine generator or the decoupling of the network electrical frequency from the rotor mechanical frequency is obtained by the power converters by injecting a controllable voltage into the rotor circuit at slip frequency.

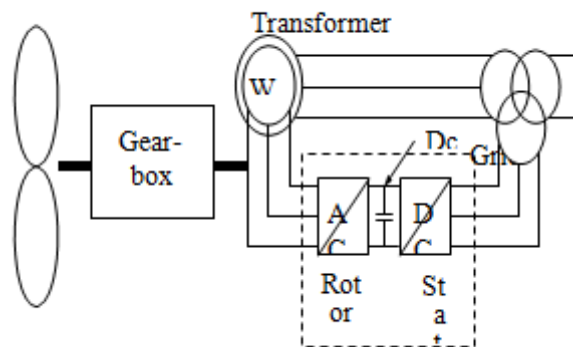

Power electronic converter DFIG Scheme

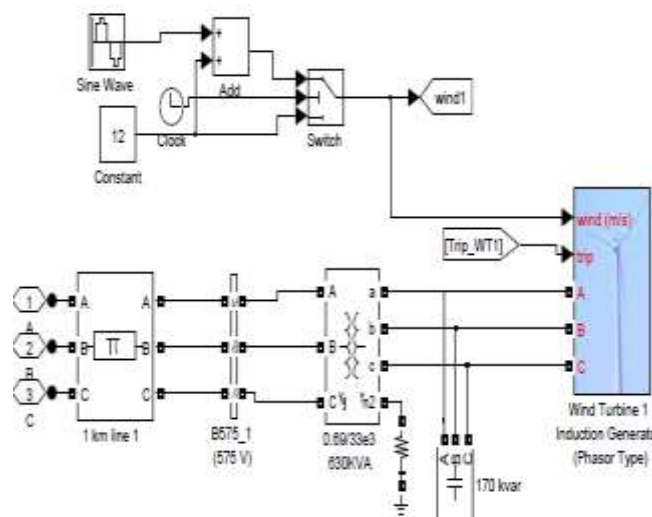
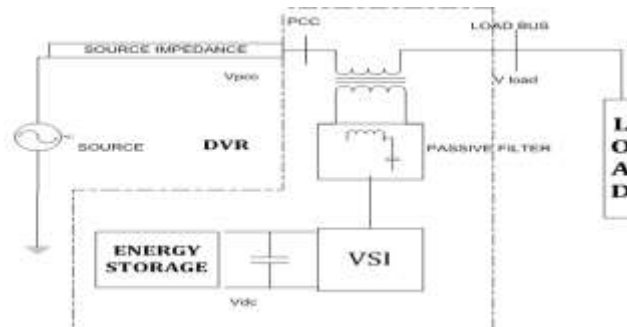

FIG system in MATLAB

Disadvantage of DFIG is its low voltage output which needs to be rectified. The control of the DFIG is mainly obtained through the control of the RSC and GSC. Although vector control is usually used to control the DFIG as it allows decoupling control of both active and reactive power and low THD, the direct control techniques have a high dynamics response but with high THD.

During the voltage dips a very high voltage may be induced in the rotor circuit which depends on the level of the voltage dip and also the type of the fault (Symmetrical or Asymmetrical). This high voltage may damage the RSC and also the DC link capacitor, therefore it should be protected during the voltage dips. For this purpose DVR is being utilized.

Dynamic voltage restorer: Dynamic voltage restorer (DVR) can provide the lucrative solution to mitigate voltage sag by establishing the appropriate voltage quality level, necessary. It is recently being used as the active solution for mitigation of power quality problems.



The basic construction of a DVR is shown in Fig.

(i) Energy Storage Unit:

This unit is responsible for energy storage in DC form. Flywheels, Batteries, superconducting magnetic energy storage (SMES) and super capacitors can be used as energy storage devices. It supplies the real power requirements of the system when DVR is used for compensation.

(ii) Capacitor: DVR has a large DC capacitor to ensure a proper DC voltage input to Inverter.

(iii) Inverter: Inverter system is used to convert dc storage into ac. Voltage source inverter (VSI) of low voltage and high current with step up injection transformer is used for this purpose in the DVR Compensation technique.

(iv) Passive Filters:

Filters convert the inverted PWM waveform into a sinusoidal waveform easily. This is achieved by eliminating the unwanted harmonic components generated VSI action. Higher orders harmonic components distort the compensated output voltage.

(v) By-Pass Switch:

It is used to protect the inverter from High current in the presence of unwanted conditions. During the occurrence of a fault or a short circuit, DVR changes it into the bypass condition where the VSI inverter is protected against over current flowing through the power semiconductor switches. The rating of the DVR inverters is a limiting factor for normal load current seen in the primary winding and reflected to the secondary winding of the series insertion transformer.

(vi) Voltage Injection Transformers:

In a three-phase system, either three single-phase transformer units or one three phase transformer unit can be used for voltage injection purpose.

Basic principal of DVR is to transfer the voltage sag compensation value from DC side of the inverter to the injected transformer after filter. The compensation capacity of a particular DVR depends on the maximum voltage injection capability and the active power that can be supplied by the DVR. When DVR's voltage disturbance occurs, active power or energy should be injected from DVR to the distribution system A DC system, which is connected to the inverter input, contains a large capacitor for storage energy. It provides reactive power to the load during faulty conditions. When the energy is drawn from the energy storage capacitors, the capacitor terminal voltage decrease. Therefore, there is a minimum voltage required below which the inverter of the DVR cannot generate the require voltage thus, size and rating of capacitor is very important for DVR power circuit

3. MODELLING AND SIMULATION RESULT ANALYSIS:

- In the considered system, the transmission line at the bus is fed by a wind source and by a programable source
- The first model under consideration is simulated directly without a compensating DVR and the output voltage is seen across the load,

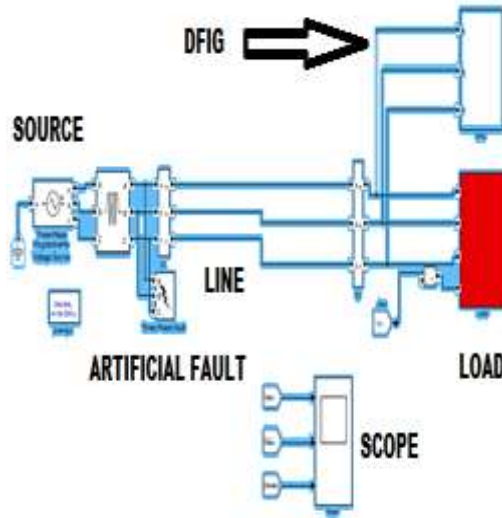

Block diagram model of transmission line under consideration

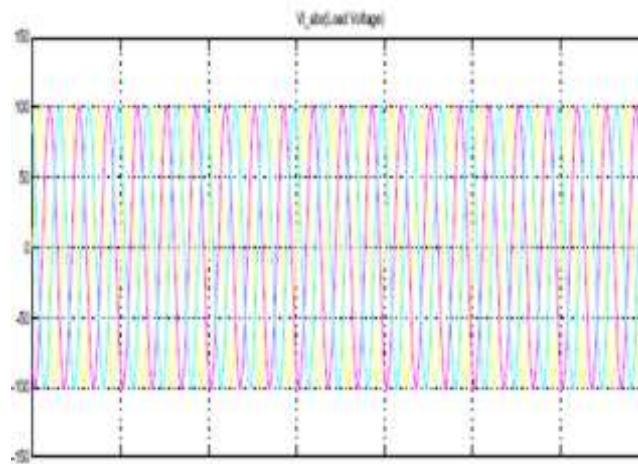

- the transmission model in the second stage is subjected to a 3-phase fault artificially at the 6th interval of running simulation and a large sag is seen.

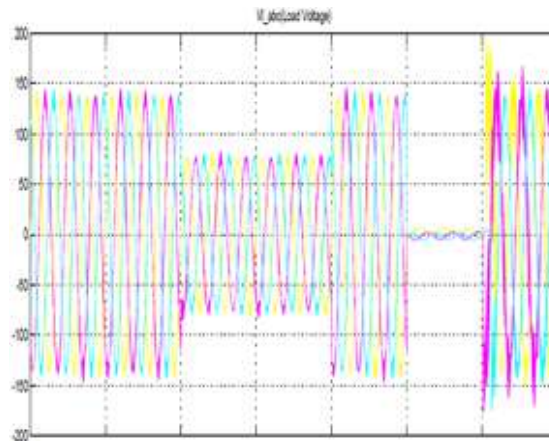

Proposed technique

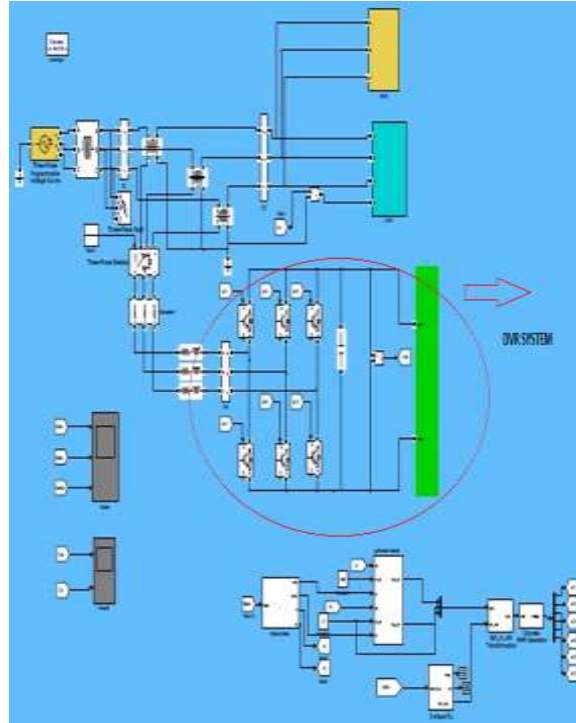

DVR implemented in the transmission line

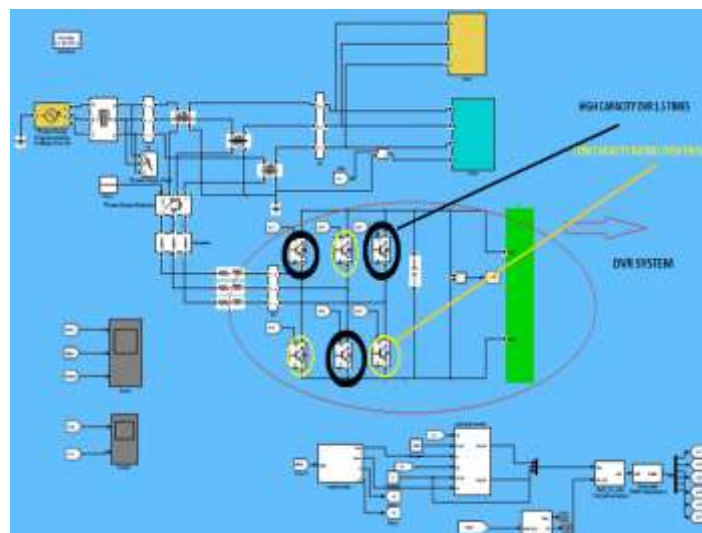

DVR with the changed ratings

- In the proposed technique, the DVR used in the MATLAB model is changed in such a way that the ratings of IGBT's 1,3, and 5 are kept 1.5 times the rating of 2,4,6
- In the second model the same condition is repeated but a DVR (dynamic voltage restorer) is used in such a way that the condition above should be satisfied
- The result obtained by the DVR in transmission line removes the sag for a 3 phase fault from the 6th interval of transmission line

4. RESULT ANALYSIS

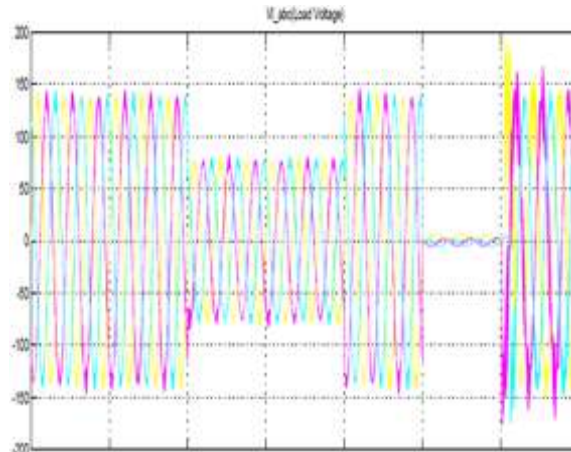

Voltage sag due to 3-phase fault without DVR

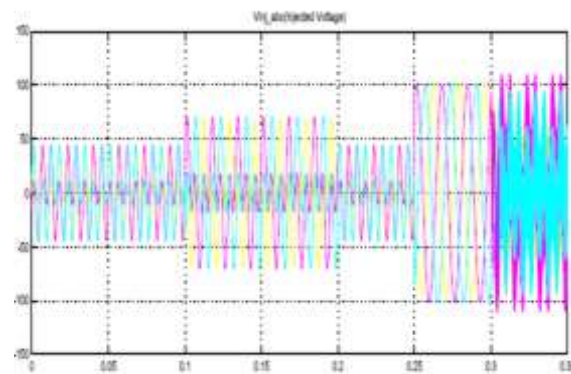

Injected voltage by the DVR at the time of fault

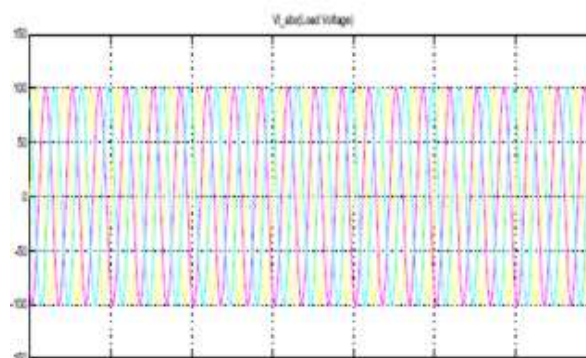

Rectified output voltage after DVR action for the same line at same 3 phase fault condition

5. CONCLUSION

In the areas where the transmission lines are subjected to more than one source the problem of voltage sag is an issue as some times in order to start the wind machines the machines take power from the grid. Also there are many disturbances which lead to the voltage sag in the transmission line and which can be rectified using a dynamic voltage restorer. DVR is formed by the switching combination of IGBT's and if the manipulation is done in these ratings then a better result is obtained



REFERENCES

- [1] Anita Pakharia, Manoj Gupta —Dynamic Voltage Restorer for Compensation of Voltage Sag and Swell: A Literature Review, International Journal of Advance in Engineering & Technology, vol 4, issue 1, July 2012, pp.347-355.
- [2] Himadri Ghosh, Pradip Kumar Saha, — Design and Simulation of a Novel Self Supported Dynamic Voltage Restorer (DVR) for Power Quality Improvement. International Journal of Scientific & Engineering Research, vol. 3, issue 6, June 2012, pp 1-6.
- [3] Mahmoud A. El-Gammal, Amr Y. Abou-Ghazala,—Dynamic Voltage Restorer for Voltage Sag Mitigation International Journal on Electrical Engineering and Informatics- volume-3, number 1, March 2011, pp 1-11.
- [4] Rosli Omar, Nasrudin Abd Rahim, — Mitigation of Voltage Sags/Swells Using Dynamic Voltage Restorer (DVR) ARPJ Journal of Engineering and Applied Sciences, vol. 4, no. 4, June 2009, pp.50-56.
- [5] M.N. Tandjaouli, C. Benachabia, — Sensitive Loads Voltage Improvement Using Dynamic Voltage Restorer 2011 International Conference on Electrical Engineering and Informatics, Bandung, Indonesia, 17-19 July 2011.
- [6] Ajay K. Damor, Prof. V. B. Babaria, — Voltage Sag Control Using DVR, National Conference on Recent Trends in Engineering & Technology B. V. M. Engineering College, Gujarat, India, 13-14 May 2011.
- [7] M. Arun Bhaskar, Dr. S.S. Dash —Voltage Quality Improvement Using DVR 2010 International Conference on Recent Trends in Information, Telecommunication and Computing. 2010, 978-0-7695-3975-1/10 \$25.00 © 2010 IEEE, pp. 378-380.
- [8] Saripalli Rajesh, Mahesh K. Mishra, —Design and Simulation of Dynamic Voltage Restorer (DVR) Using Sinusoidal Pulse Width Modulation (SPWM) 16th National power systems conference, Osmania University, Hyderabad, A.P. India, 15-17 December 2010, pp. 317-322.
- [9] Ali O Al-Mathnani, Hussain Shareef —Power Quality Improvement using DVR with Two Fast Vector Control The 4th International Power Engineering and Optimization Conf., Selangor, MALAYSIA, 23-24 June 2010, pp. 376-381.
- [10] Yash Pal, A. Swarup, Bhim Singh, “A Review of Compensating Type Custom Power Devices for Power Quality Improvement”, 2008 IEEE 978-1-4244-1762-9/08.
- [11] Roger C. Dugan, Mark F. McGranaghan, Surya Santoso, H. Wayne Beaty, — Electrical Power Systems Quality Tata McGraw Hills publications, 3rd Edition 2012

CITE AN ARTICLE

Ahamad, S., Verma, A. K., & Yadav, B. (2018). USING A DYNAMIC VOLTAGE RESTORER (DVR) FOR REMOVAL OF ABNORMALITIES DUE TO VOLTAGE SAG IN A DOUBLY FED TRANSMISSION LINE. *INTERNATIONAL JOURNAL OF ENGINEERING SCIENCES & RESEARCH TECHNOLOGY*, 7(10), 30-37.